

# Top<sup>®</sup>

**AUTOMAZIONI**

BAR FEEDERS & AUTOMATIONS



**NO MORE REASONS  
TO WAIT**

# Rolling

**ROLLING IS ONE OF TOP AUTOMAZIONI'S  
ROBOTIC SOLUTIONS**

**INTEGRATED STORAGE MADE OF A  
SERIES OF PALLETS IN-LINE FOR  
THE LOADING/UNLOADING OF  
COMPONENTS**

**CONFIGURABLE WITH ALL  
NUMERICALLY CONTROLLED  
MACHINES SUCH AS  
LATHES, MACHINING  
CENTERS, GRINDERS,  
AND OTHERS  
EQUIPMENT**

**i4.0**



## LAYOUT AND INSTALLATION

ROLLING is available in several versions (SL - Left, SC - Central, SR - Right) to adapt to any CNC machine tool and related workshop environment.

The onboard position of the Fanuc always leaves the intervention area on the CNC machine free, when the ROLLING is not in use. This aspect allows regular and comfortable operation on the HMI panel, convenient set up of the CNC machine and quick equipment's checks.

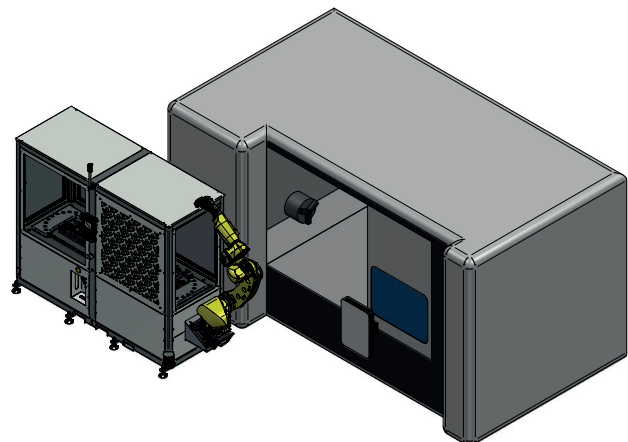



Scan the QR CODE to watch the video



ROLLING

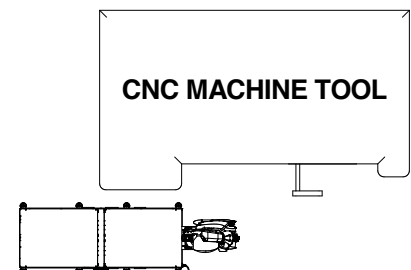
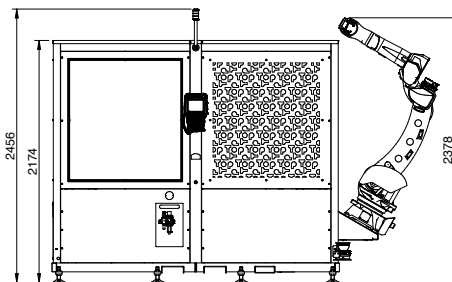
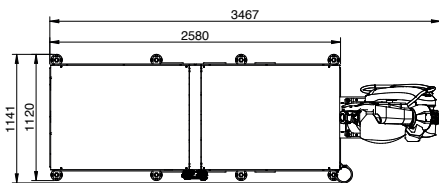



## ROBOT FEATURES

- Fancu M-20iD25
- Payload 25 kg
- Max reach 2.000mm, center tool point
- Max speed (J6) 615 °/s
- Repeatability +/-0,02mm
- Wrist protection class IP67
- Weight 210 kg

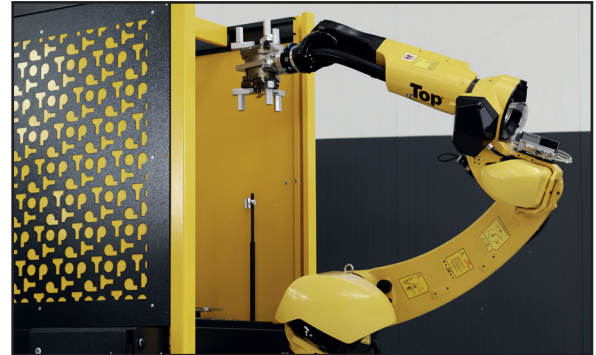

## CONTROL UNIT

- Up to 5 CNC machine tools connectable
- Controller R30iB-PLUS
- Intuitive programming
- Friendly interface
- Fancu collaborative functions
- Touchscreen
- Machine utilization statistics
- Intelligent maintenance prediction software
- Eccentric loading and unloading mode
- Park positioning function
- Pallets-in-line full handling



## GRIPPER FEATURES (TAILORED ON THE PROJECT)

- 2-fingers gripper for rectangular shapes
- 3-fingers gripper for round shapes
- 2-fingers gripper for long shafts
- Customized gripper for specific shapes
- Air blow system
- Quick change system for gripper
- Low air pressure detection

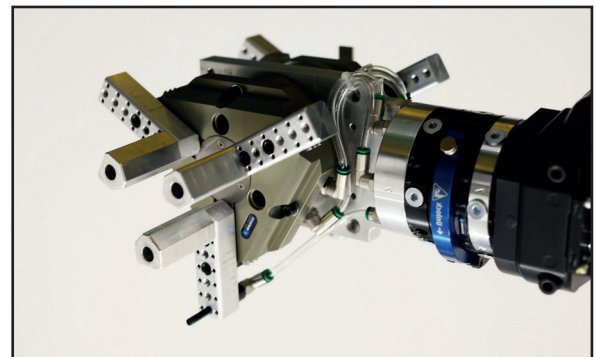

## ADDITIONAL WORKING STATIONS

- Parts unloading on box/cage/belt
- Parts positioning on measuring station
- Other tailored customers operations available

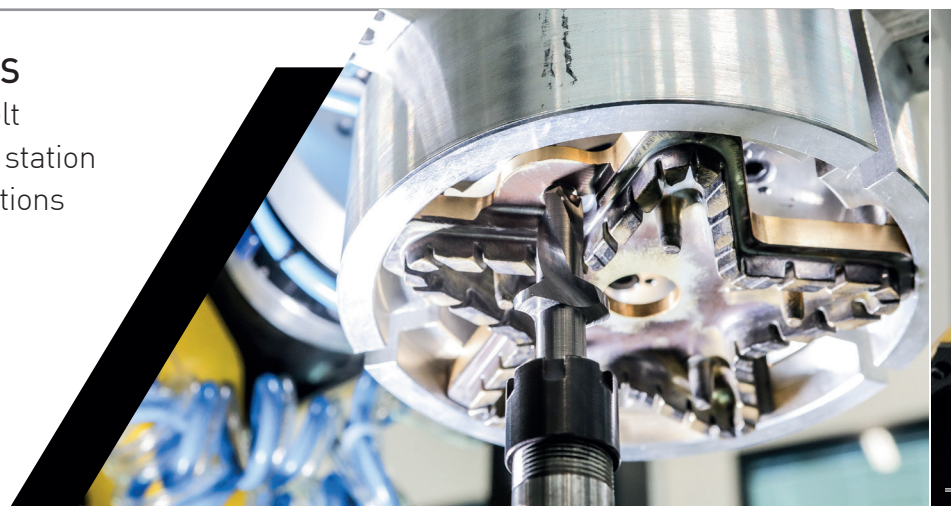

## REVOLVING STACKING PALLETS

- Payload 165 kilos each
- Pallets translation managed by step-driven motor and industrial chain
- Optoelectric barriers for fast and safe workpieces loading

## PALLETS FEATURES

- Modular structure with 12 or 16 or 20 pallets
- Pallet dimensions 250x250 mm
- Height loading up to 450mm
- Workpieces stacking capability up to:
  - 2 rods version: 200mm
  - 3 rods version: 250mm
  - 4 rods version: 220mm
- Maximum capacity for single pallet 165 kg
- Quick self-centering system
- Carbonitrided frames for maximum durability



ROLLING

## SAFETY FEATURES

- Fanuc Dual Check Safety System integrated with laser scanner
- Pneumatic or servo-motor driven CNC machine door opener with integrated safety circuit

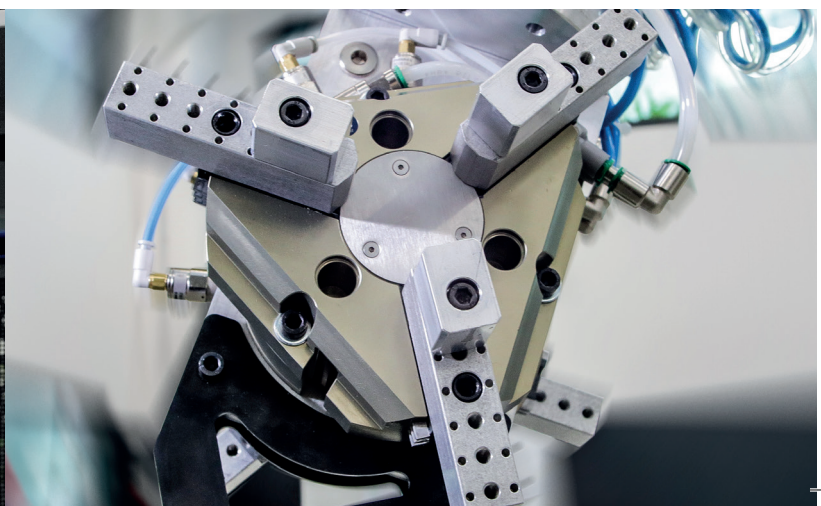
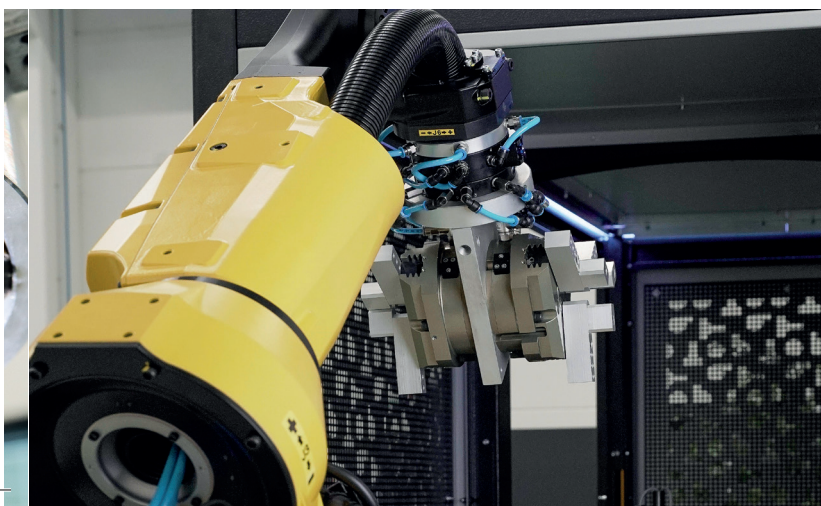



HOW TO FIND US ►  
scan QR code



**TOP AUTOMAZIONI S.R.L.**

Via Torrianese, 62  
47824 Poggio Torriana (RN)

Tel. +39 0541 688248

Fax +39 0541 688168

topautomazioni@topautomazioni.com

www.topautomazioni.com

